

Figure 18

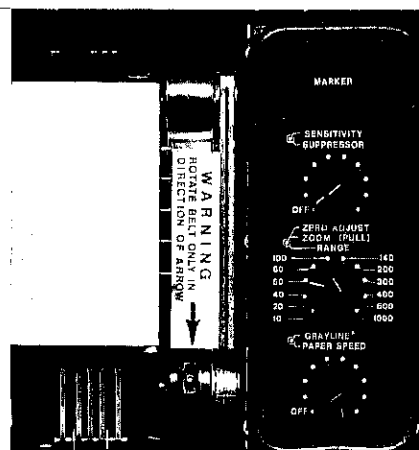

Figure 19

— the stylus may be damaged. (See Figure 19.)

SPECIAL NOTE: The stylus may be damaged if the platen assembly is pulled down unless the stylus has been moved to the back side of the platen.

4. Pull out and down on the tab at the top center of the platen assembly to expose the paper spools. (See Figure 20.)
5. To remove the full take-up roll and the empty supply spool, press the two metal tabs together on the top of the platen assembly, and pull out and down on the paper retainer. (See Figure 21.) The full take-up roll can now be easily removed from the paper core shafts. (See Figure 22.)
6. Pull the empty supply core from the right side in the same manner. Install

Notice—Use only genuine Eagle EGP-1 graph paper

Substitute paper does not give satisfactory performance in Eagle graph recorders.



Figure 20

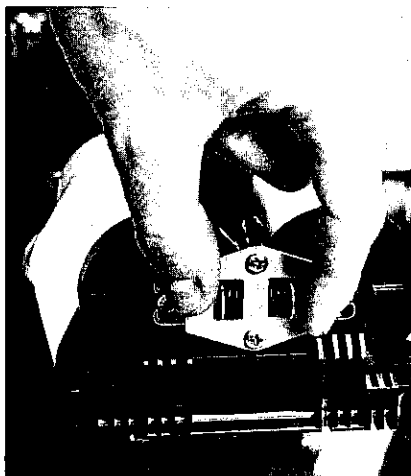

Figure 21

the empty core onto the take-up shaft. (See Figure 23) Align the two notches in the core with the tabs on the lower take-up spool.

7. Slide a fresh roll of paper in position on the supply side shaft on the right side of the platen assembly. The paper must spool off the bottom of the roll. (See Figure 24)
8. Draw the end of the paper across the face of the platen, around the friction roller, over the take-up core, and tape it squarely to the take-up core. (See Figure 25) Small pieces of tape may be stored inside the housing for this purpose. Close the top of the platen assembly by pressing the two tabs together on the paper retainer and returning the retainer back to the operating position. (See Figure 26)
9. Turn the small knob at the upper left hand side of the platen assembly to put a small amount of tension on the paper. It should be snug against the platen. (Figure 27)
10. Push the platen assembly back to its operating position. Be sure it engages the catch inside the top of the case. (See Figure 20)
11. Close the front of the case. Latch both catches on the top of the case.
12. Turn the unit on. Move the Chart Speed knob fully clockwise. Watch the paper long enough to be sure it is moving smoothly and evenly across the platen. If the paper flutters or begins to run "uphill", repeat step 8.

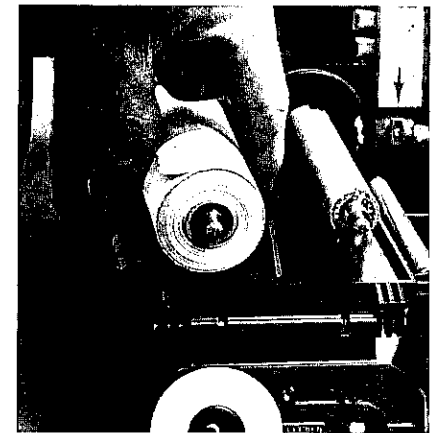

Figure 22

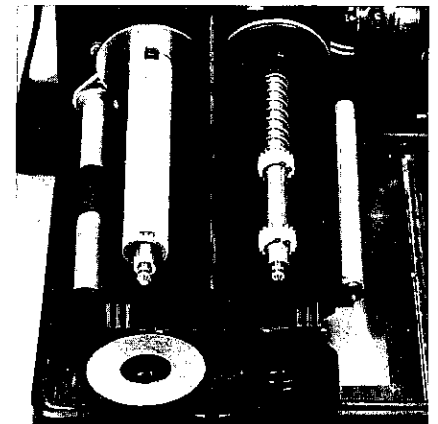

Figure 23

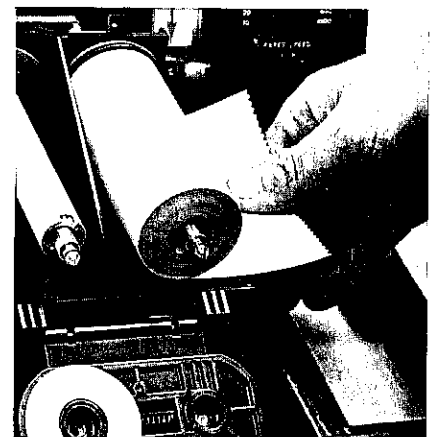

Figure 24

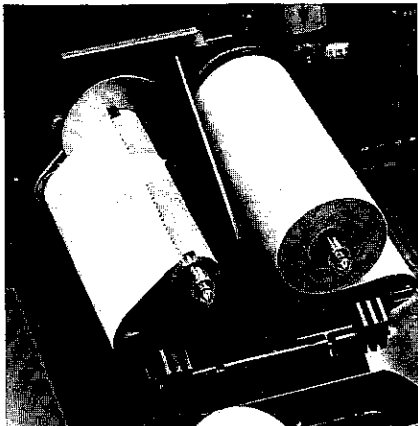

Figure 25



Figure 26

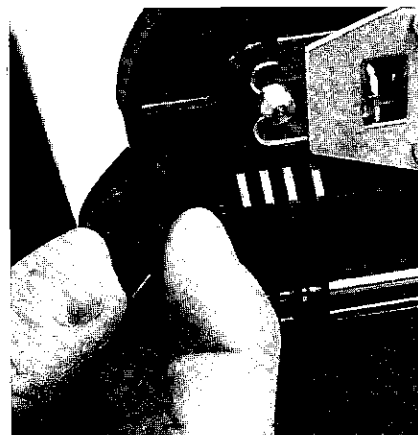

Figure 27

STYLUS REPLACEMENT

CAUTION — High voltage is present in the electronic section when the unit is turned on.

1. **TURN THE UNIT OFF.**
2. Release both catches on the top of the case. Pull out and down on the top of the case front to expose the stylus belt. (See Figure 18.)
3. The stylus belt rides over two wheels located at the right edge of the platen assembly. Move the front of the belt **DOWN** to position the stylus at the center of the platen.
4. Hold the stylus belt stationary with one finger, and remove the old stylus by starting at its left edge and moving it out from under the tabs on the stylus holder.
5. Before installing the new stylus, be sure it is bent properly by comparing it to Figure 28.
6. Refer to Figure 29 to be sure the new stylus is positioned correctly under the tabs on the holder. Be sure it moves freely in the two slots. If not, bend the stylus away from the edge it is rubbing on until it does move freely.
7. After installing, if the stylus won't print all the way down the paper as shown in Figure 30, bend the right leg down so that more pressure is exerted against the stainless steel plate. If it still does not print all the way, bend the left leg down more (but not so far that it digs into the paper).
8. Close the front of the case. Latch both catches on the top of the case.

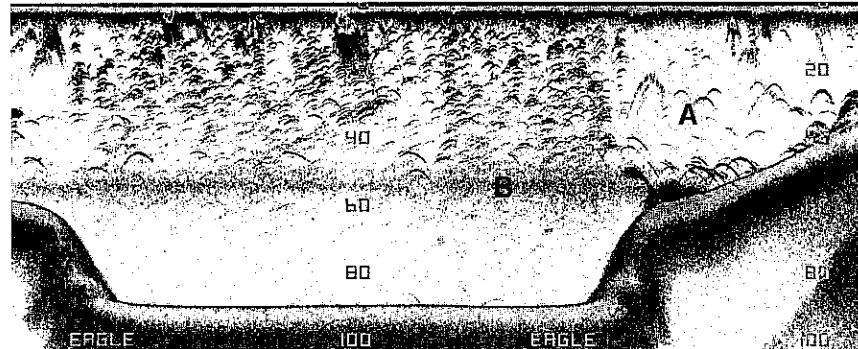

Figure 17

EAGLE is that it can record individual fish with a characteristic arched mark that separates them from their stationary surroundings. The reason for this is shown below. The distance to a fish when it moves into the sonar's cone of sound is shown as "A" in Figure 16. When the fish has moved to the center of the cone, the distance to it will be shorter, (line "B"), and as it moves out of the cone, the distance will increase again as shown in line "C". If a partial arch occurs most of the time on your unit (the mark curves up, but does not curve back down or vice-versa), it is because the transducer is not aimed straight down.

Sharp, well-defined signatures will occur most often when the Sensitivity knob is set at the $\frac{3}{4}$ point, or higher. (See "A", Figure 17). Remember, too, that there must be some movement between the fish and boat to develop the arched mark.

Thermoclines

The temperature of water in the lake is seldom constant from top to bottom. Layers of different temperatures form, and the junction

of a warm and cool layer of water is called a thermocline. The depth and thickness of the thermocline can vary with the season or time of day. In deep lakes there may be two or more, at different depths. Thermoclines are important to the fisherman because they are areas which fish are active. Many times bait fish will be above the thermocline while larger game fish suspend just below it. See "B", Figure 17.

Your EAGLE Mach 1 can detect this invisible layer in the water, but the Sensitivity knob will probably have to be set at the $\frac{1}{2}$ point, or higher.

PAPER LOADING

CAUTION — High voltage is present in the electronic section when the unit is turned on.

1. **TURN THE UNIT OFF.**
2. Release both catches on the top of the case. Pull out and down on the top of the case front to expose the platen assembly. (See Figure 18.)
3. Move the stylus belt **DOWN**, to position the marking stylus on the back side of the platen. **NEVER** move the belt up

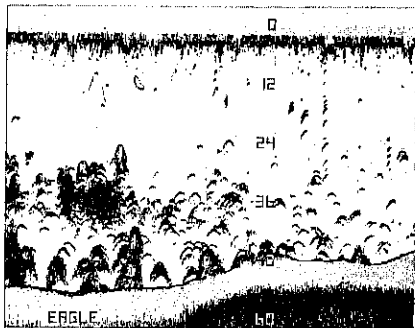

Figure 14

ZOOM "OFF"



Figure 15

ZOOM "ON"

ZERO ADJUST

Occasionally, when changing the stylus or stylus belt, the zero does not print at the same place near the top of the chart paper. By rotating the BOTTOM ZOOM control counter-clockwise the zero line can be moved towards the top of the chart paper, clockwise rotation moves the zero line towards the bottom of the paper. The control has been designed so that even if the record goes off the bottom of the paper, it can still be adjusted to print on the paper. The ZERO ADJUST control will function if the BOTTOM ZOOM feature is on or off.

MARKER

Pressing the Marker button causes a vertical line to be printed on the paper. Hold the Marker button down and the unit will print the vertical line for as long as the button is held down.

END OF PAPER MARKER

The graph paper used in the MACH 1 has a red line printed at the bottom of the paper to signify when there is only 2 to 3 feet of paper remaining.

IV HOW TO READ GRAPHS

"Arched Signatures"

A remarkable advantage of the



Figure 16

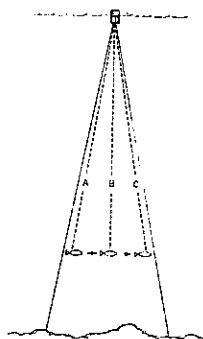

Figure 28

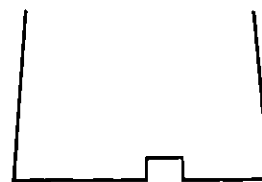

Figure 29

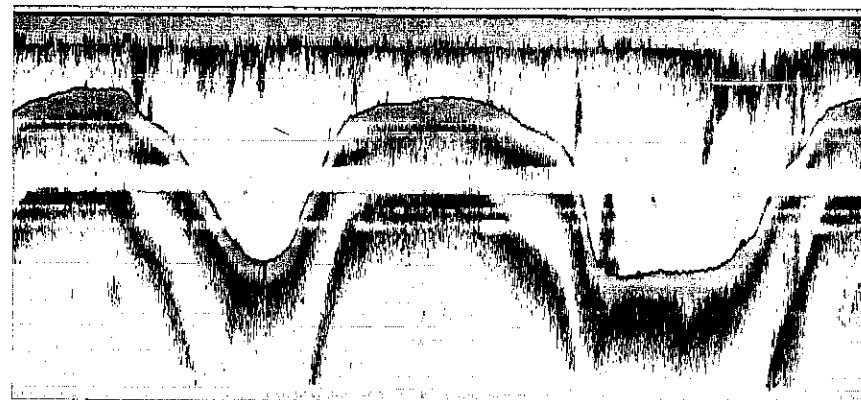
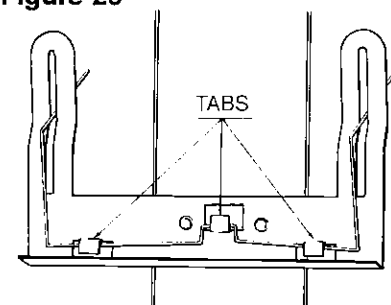

Figure 30

STYLUS BELT REPLACEMENT

CAUTION — High voltage is present in the electronic section when the unit is turned on.

1. TURN THE UNIT OFF.
2. Release both catches on the top of the case. Pull out and down on the top of the case front and the platen to expose the stylus belt.
3. The stylus belt rides over two wheels located at the right edge of the platen assembly. Refer to Figure 1 on page 2. Move the front of the belt DOWN to position the stylus at the center of the platen.
4. Grasp the belt at the stylus holder with the thumb and forefinger and move it gently
5. Position the new belt on the

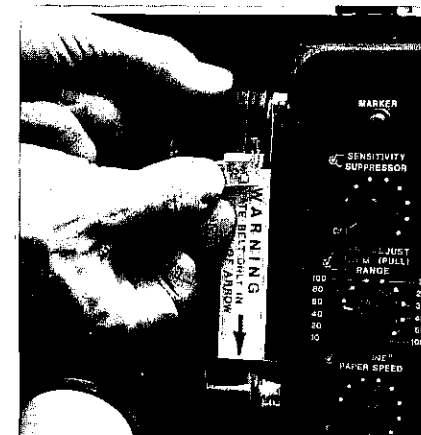

Figure 31

to the left while pushing the belt off the wheels with the other forefinger. (See Figure 31.)

5. Position the new belt on the

wheels by reversing the procedure used to remove the old one. **BE SURE** the fingers of the new stylus are pointed UP.

6. Close the front of the case. Latch both catches at the top of the unit.

MAINTENANCE

NOTE: The stylus may be damaged if it is in front of the platen when the platen assembly is pulled down. Always move the stylus to the back side of the platen when changing the paper rolls. Remember to move the belt down to remove the stylus.

Black carbon dust is created during the recording process. Use a soft, oil-free rag to clean the viewing door and metal platen behind the paper. Low pressure compressed air may be used to blow dust out of the case and away from moving parts if the air is dry and free of oil.

After every five rolls of paper, the stylus belt and the wheels it rides on should be wiped clean with a soft rag moistened with alcohol to remove carbon dust. Strong solvents or abrasive cleaners should not be used.

All mechanical connections should be checked periodically to be sure they haven't worked loose.

HIGH VOLTAGE is present in the transmitter section when the unit

is ON. No attempt should be made by any unauthorized person to modify or repair the electronic section.

All electrical connections should be checked periodically and cleaned as necessary.

The face of the transducer, if mounted on the transom should be washed periodically with mild soapy water to remove any accumulated rod grime or oily film. This is essential to have good contact between the transducer and the water.

Periodically, the rubber roller on the paper drive should be cleaned with a cloth dampened with alcohol, to improve the friction on the drive shaft.

DO SECTION

Do carry a spare fuse, stylus belt, and roll of paper.

Do use the empty cardboard core from the last roll of paper on the take-up post.

Do keep the recorded graphs for future reference.

Do clean the stylus belt, wheels, and the rubber roller after every five rolls of paper.

DON'T SECTION

DON'T OPEN THE CASE WHEN THE UNIT IS ON.

Don't pull the platen assembly down when the stylus is at the front.

Don't store any objects inside the case or behind the viewing window. (Except for small pieces of tape.)

Don't forget to tape the paper to

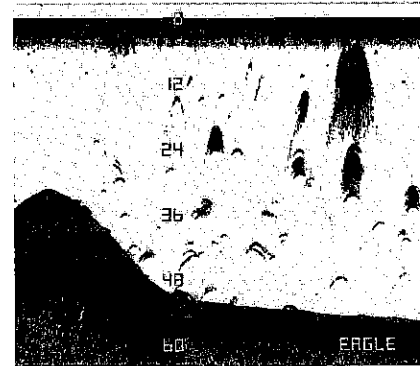

Figure 11 GRAYLINE "OFF"

per speed may also be slowed when not looking for fish or to simply conserve paper.

GRAYLINE CONTROL

The GRAYLINE function can be used to outline the bottom contour which might otherwise be hidden beneath trees and brush; it can also give clues to the composition of the bottom. A hard bottom returns a very strong signal causing a wide gray line. A soft, muddy, or weedy bottom returns a weaker signal which is emphasized with a narrow gray line. Do not advance the control too far or it will gray line on the target completely, showing no black, which makes the target difficult to see.

There are 12 ranges:

- 0-10 feet
- 0-20
- 0-40
- 0-60
- 0-80
- 0-100
- 0-140
- 0-200
- 0-300
- 0-400
- 0-600
- 0-1000

Figure 13

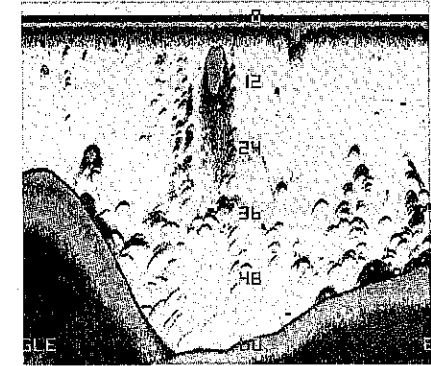

Figure 12 GRAYLINE "ON"

RANGE

This control determines the depth scale displayed on the chart paper. (See Figure 13)

BOTTOM ZOOM

By pulling out the knob, the feature allows you to "Zoom in" on the lower half of the range being displayed on the graph. In other words, with the Range control set to the 60 foot range, and the Bottom Zoom control pushed in (OFF), the scale printed on the chart paper will be 0 to 60 feet. (See Figure 14.) With the Bottom Zoom control pulled out (ON), the scale will be 30 to 60 feet. This allows you to double the size of any target or feature in the lower half of any depth range. (Figure 15.)

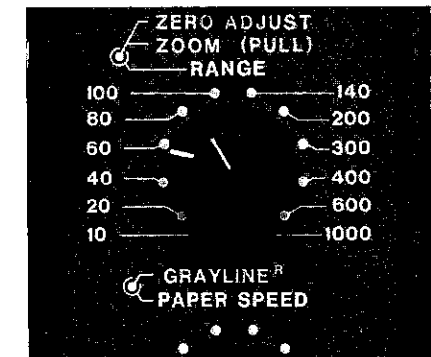

Figure 13

sound pulse has to travel, the weaker it becomes. By broadening the pulse width, in essence, a larger signal is transmitted and it is easier for the receiver to detect it.

For this reason, the micro-computer in the MACH 1 automatically increases the initial pulse width of the unit as deeper ranges are selected by the operator.

NOTE: Initial pulse width is the pulse width of the unit when the Suppressor control is turned to minimum.

RANGE (feet)	INITIAL TRANSMIT PULSE WIDTH (micro-seconds)
10	110
20	150
40-200	200
300	300
400	400
600-1000	600

The transmitter pulse width can be increased from the initial point at any time by rotating the Suppressor control clockwise. The maximum amount of pulse width

the range control is set to 300 feet, and the Suppressor control is rotated to the maximum clockwise position, the transmitter pulse width would be 1100 micro-seconds. (300 initial plus 800 equals 1100 micro-seconds.)

Paper Speed Control

This knob adjusts the speed of the chart paper. For good detailed graphs, in shallow to medium depths, turn the paper speed control up to at least 3/4 when trolling. For best details, turn it up to maximum. This will show proper fish arches at low speeds and keeps high speed information from being compressed. The paper speed should be turned down when using the unit in deep water. This will prevent gaps from appearing in the record. In fact, the microcomputer will automatically slow the maximum speed of the chart paper when operating in deep water. The chart below gives the points where the maximum speed of the paper is slowed.

The chart paper may be slowed even further by adjusting the paper speed control. Remember, if

APPROXIMATE PAPER SPEED

RANGE (feet)	Minimum Paper Speed		Maximum Paper Speed	
	Inches Per Min	Hours Per Roll	Inches Per Min	Hours Per Roll
10-100	1.0	10	3.0	3.3
140-200	0.5	20	2.0	5.0
300-600	0.2	50	1.2	8.3
1000	0.2	50	0.75	13.3

Figure 10

added to the initial transmitter pulse width is approximately 800 micro-seconds. In other words, if

gaps appear in the record, turn the paper speed down until a solid record is achieved. The pa-

the take-up core.

Don't rotate the stylus belt up.

Don't use oily cloths, strong solvents, or abrasive cleansers.

TROUBLESHOOTING SECTION

Symptom

On/Off switch is "ON", but the stylus and paper don't move.

What To Do

Check fuse; check connections at battery for tightness and corrosion.

Symptom

On/Off switch is "ON", have zero mark, but no echoes or bottom signal.

What To Do

Be sure the transducer is plugged into the unit and the transducer is in contact with the water.

Symptom

The unit is "ON", but paper does not move.

What To Do

Tape paper to cardboard spool on take-up post.

Symptom

Recorder marks are faint or dim.

What To Do

Clean viewing door; replace the stylus; check battery connections.

Symptom

Recorded marks are very heavy; paper is torn by stylus.

What To Do

Bend the stylus slightly to reduce pressure on paper.

VI ADVANCED OPERATION

The EAGLE MACH 1 takes advantage of the micro-processor's power, giving you options that allows it to outperform the vast majority of graph recorders in the sportfishing field. To use the functions in this section two controls must be used simultaneously. We urge you to read this section carefully to take advantage of the superior performance of the EAGLE MACH 1.

Lines

When the unit is first turned on, depth lines are printed automatically on the paper. If you desire to turn the lines off, rotate the range control to 20 feet, hold the marker switch "ON", and rotate the range control to the 10 feet position. The marker switch must be "ON" during the switch from 20 to 10 feet. The MACH 1 will stop printing the

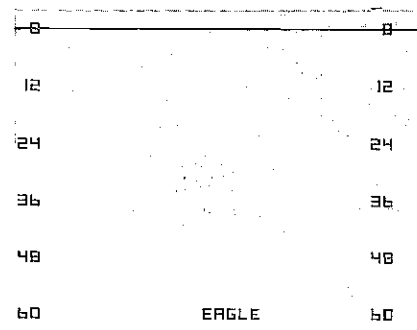

Figure 32

LINES "OFF"

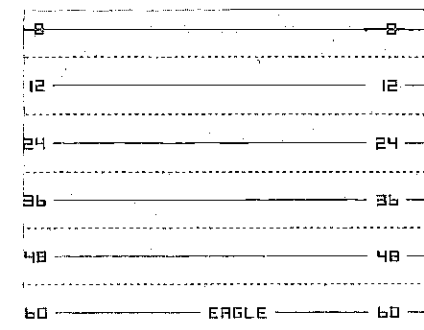

Figure 33

LINES "ON"

lines immediately. Turn the range control back to your original depth setting.

To turn the lines back on, simply reverse the procedure by turning the range control to 10 feet, hold the marker switch "ON", and rotate the range control to the 20 feet position. Lines will be printed on the paper. Return the range control to the desired depth setting.

Scale

The numbers that indicate the depth or scale may be deleted if desired. Rotate the range control to the 60 feet position, hold the marker control "ON", and turn the range control to the 40 feet position. The depth scale will no longer be printed. The range control now may be turned to the desired depth setting.

To turn the depth scale back on, rotate the range control to 40 feet, hold the marker switch "ON", and rotate the range control back to the 60 feet position. Remember, the marker switch must be on during the period of time that the range control is switched. Return the range control to the desired depth setting.

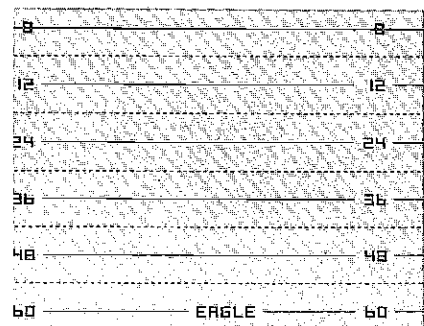

Figure 34 SCALE "ON"

Transmit and Print Alternate

When using the MACH 1 in deep water, it may be desirable to slow the paper speed down considerably. However, when doing so, you may get "over print" or very dark, heavy printing over an area that is difficult to read. Much detail can be lost due to this.

An available feature is the Transmit and Print Alternate function which, when activated, triggers the transmitter and causes the stylus to print every other revolution. This accomplishes three things:

1. Since the stylus only prints every other revolution, the recorded information is not squeezed together into a very small area. This allows better records at slower paper speeds. Also, the scale numbers are spread out more, so they are more legible.
2. Prevents the possibility of "wrap around". This is the undesirable occurrence of the second or third bottom echo printed on the paper at the top or middle of the page. Many times this can interfere with fish or other targets that you wish to see.

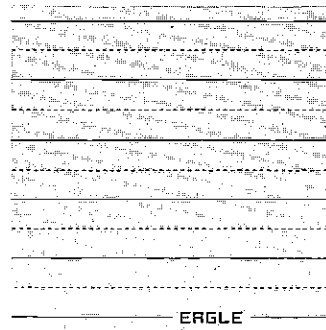

Figure 35 SCALE "OFF"

Suppressor Control

The Suppressor Control is used to reduce interference from noise. Noise, in electronic terms, is any undesired signal. It can be caused by an electrical source, (such as the engine's ignition system), or by air bubbles in disturbed water which is called cavitation noise. In both cases, the noise could produce unwanted marks on the paper. (See Figure 7). Fortunately, noise

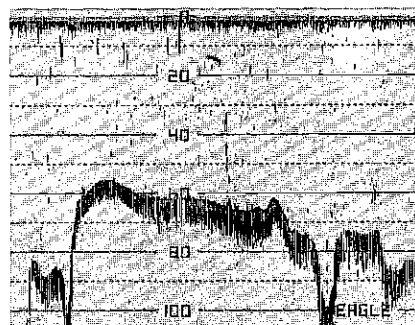
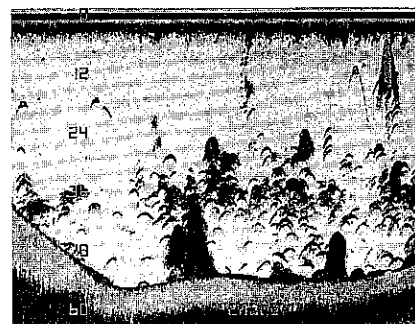

Figure 6

pulses are relatively short in time compared to real sonar signals. Advancing the Suppressor knob will cause the system to reject these unwanted, short pulses without reducing the sensitivity in any way. However, with high suppression settings, the graph record becomes coarse and the



PROPER SETTING

Figure 8

ability to separate fish from the bottom or from other fish will be decreased. (See Figure 9). Therefore, the lower the suppression setting, the better. Advance the knob setting only as far as necessary to remove the erratic, unwanted noise marks. Most of the time at low or trolling speeds, no suppression will be needed.

However, it is helpful sometimes to have longer pulse widths when noise is not a concern. When us-



Figure 7

ing a sonar in deeper water, it is easier for the unit to detect a longer pulse coming back from the bottom or from the fish. This is called "Probability of Echo Detection". The probability of the unit being able to detect an echo returning from deep water is diminished because the further the

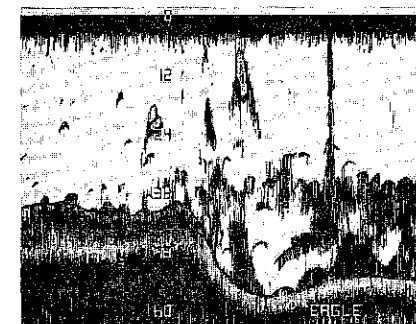

SUPPRESSION: TOO HIGH

Figure 9

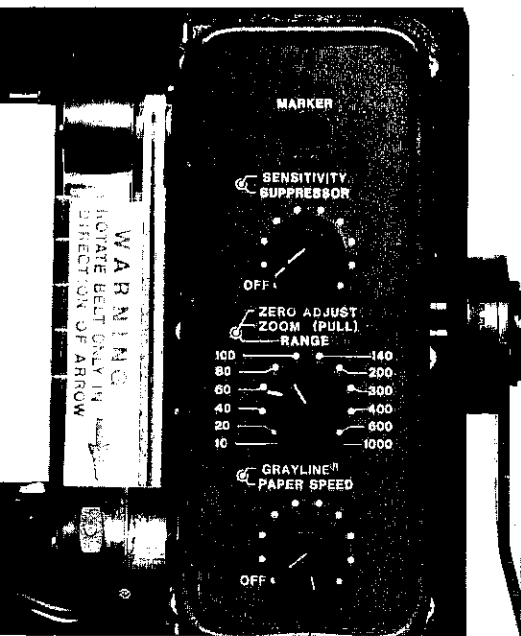
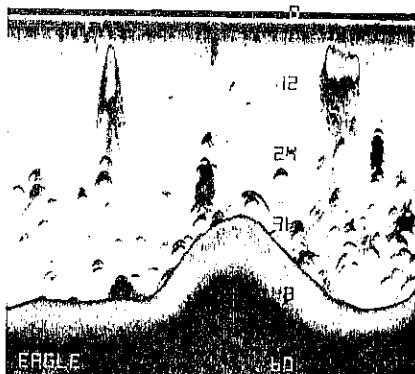

Figure 3

BASIC OPERATION

ON-OFF and SENSITIVITY Control

Rotate the ON/OFF knob clockwise to turn the unit on. The Sensitivity knob works much like the volume control on a radio, that is, weaker signals will be detected



SENSITIVITY: PROPER SETTING

Figure 4

with higher settings of the knob. When cruising, or at other times when just simple bottom-contour information is desired, the Sensitivity setting can be low. In deep water or over soft, muddy bottoms which produce weak echoes, the setting will have to be higher.

When high Sensitivity settings are used, a second bottom echo will appear. This is normal and is caused by the returning signal reflecting off the surface of the water, making a second trip to the bottom and back.

When detailed information about brush piles, individual fish or the thermocline is desired, the Sensitivity knob should be set approximately to the $\frac{3}{4}$ point. Refer to the illustration below to see what effect the Sensitivity setting has on the recorded information.

Recording individual fish with an "arched" signature can usually be accomplished at trolling speeds with the Sensitivity knob at the $\frac{3}{4}$ point, or higher. Refer to the section "Arched Signatures" for more information about this important function of your recorder.

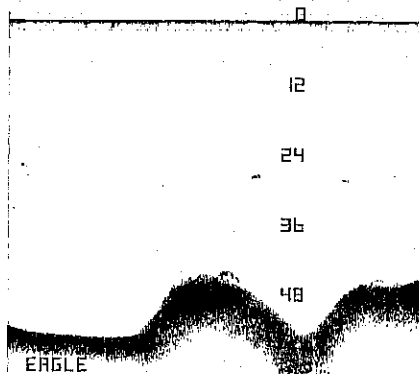

SENSITIVITY: TOO LOW

Figure 5

3. Reduces the reverberation effect. This happens mainly on lower frequency units, although it does sometimes show up on high frequency graphs.

To use the Transmit and Print Alternate function, turn the range control to 100 feet. Next, hold down the marker switch and turn the range control to 80 feet. Now release the marker switch. Return the range control to your original setting. The MACH 1 will now be in the Transmit and Print Alternate mode. Remember, the marker control must be "ON" dur-

ing the period of time that the range control is turned from 100 to 80 feet.

To return the MACH 1 to normal operation, simply reverse the operation by turning the range control to 80 feet, hold the marker switch "ON", rotate the range control to 100 feet, and release the marker switch.

NOTE: A simple way to return any of the optional features back to normal operation is to turn the sensitivity control to the "OFF" position and then turn it back "ON". This turns off the power to the unit, erasing all of the op-

APPROXIMATE PAPER SPEED

RANGE (feet)	Minimum Paper Speed		Maximum Paper Speed	
	Inches Per Min	Hours Per Roll	Inches Per Min	Hours Per Roll
10-100	0.6	17	2.0	5.0
140-200	0.4	25	1.2	8.3
300-600	0.2	50	0.75	13.3
1000	0.2	50	0.75	13.3

Figure 36

(with Alternate Transmit and Print)

By comparing this chart with the one on page 6, you can see that a significant amount of paper can be saved by using the Alternate Transmit and Print function.

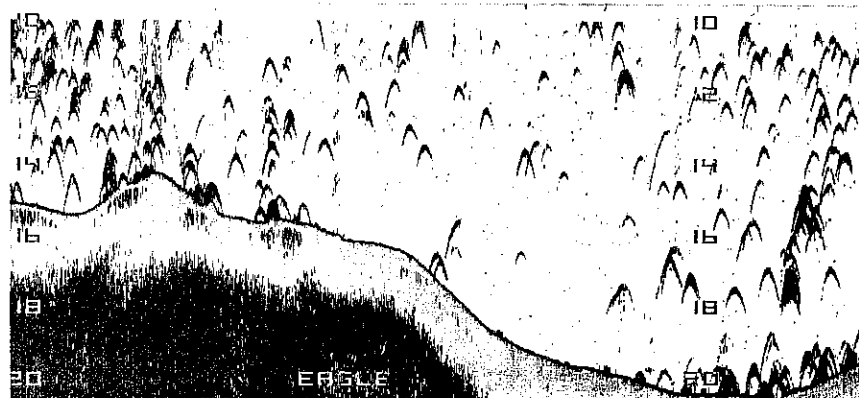

Figure 37

tional features that you have programmed in. Just remember, if you have turned the lines and the scales off, and you wish to turn only the scales back on, don't turn off power to the unit or you will have both lines and scales on

when you turn the unit back on. Turning the unit off and then on again only works as a quick method when you only have one feature on, or all of the optional features that you wish to return to normal.

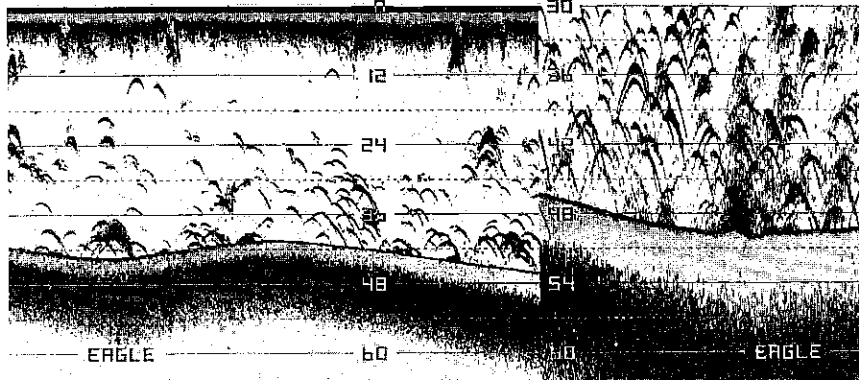

Figure 38

RANGE: 60 FEET
ZOOM: OFF
SENSITIVITY: 1/2
SUPPRESSOR: MINIMUM
PAPER SPEED: 3/4
GRAYLINE: MINIMUM

RANGE: 60 FEET
ZOOM: ON
SENSITIVITY: 1/2
SUPPRESSOR: MINIMUM
PAPER SPEED: 3/4
GRAYLINE: MINIMUM



Figure 39

RANGE: 30 FEET
SUPPRESSOR: MINIMUM
SENSITIVITY: 3/4

LINES: OFF
PAPER SPEED: 3/4
ZOOM: ON
GRAYLINE: MINIMUM

described in Section VI — Advanced Operation. This chapter will explain the other features that will enable the serious operator to get the maximum use out of your EAGLE.

We urge you to read this manual thoroughly and familiarize yourself with the controls. Although this is a very advanced unit, it is easy to use, thanks to the power of the microcomputer and the front panel controls. Should you require extra help, please phone our Customer Service Department toll free — 1-800-331-2301. Oklahoma residents call collect 918-266-5373. A service representative will be happy to help you.

INSTALLATION

Mounting —

The depth sounder may be installed in any convenient area, provided the unit can be tilted for the best viewing angle. Holes in the bracket allow wood screw or thru bolt mounting. A wood stiffener may be required on the back of thin fiberglass panels to support the unit.

If the desired location is closer than 18" to a magnetic compass, a trial run should be made with the unit in operation to be sure that the compass readings are

not affected.

POWER CONNECTIONS

12 volt DC power for the sonar unit should be supplied from the boat's 12 volt DC electrical system. The power cable may be attached to an accessory or power buss, but if you have problems with electrical interference, the cable should be attached directly to the battery.

If a longer cable is required, use ordinary #18 lamp cord available at any hardware or electronic supply store. Splices should be soldered. If this can't be done, use crimp type splices. Tape all connections with electrical tape.

An in-line fuse holder with fuse is supplied with the EAGLE graph. Be certain to install this fuse holder as close to the power source as possible. This will protect both the sonar unit and the power cable in the event a short occurs. Crimp connectors are supplied to attach the fuse holder to the power cable. The red wire in the power cable is the positive conductor. The black wire is the ground or negative conductor.

The graph is protected from accidental polarity reversals and no damage will occur if the wires are reversed. However, the unit will not operate until the proper polarity is applied.

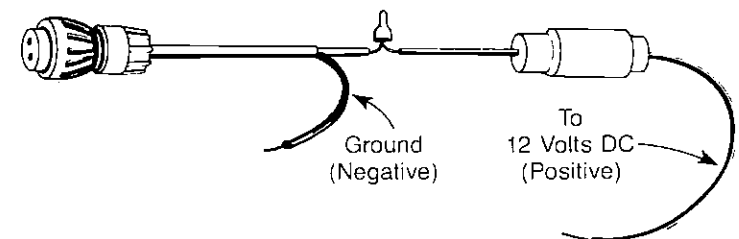

Figure 2

1. INTRODUCTION

Small boat sonar systems are routinely used to measure water depth, examine bottom contours, and locate fish. The Eagle MACH 1 recorder goes far beyond the ordinary in displaying these objects, plus many more such as schools of baitfish, algae and plankton, thermoclines, individual fish closer than six inches apart, and much more. These features combine to make the MACH 1 a superior graph recorder for today's sportfishing industry.

2. HOW IT WORKS

When the unit is turned on, an electronically regulated motor drives a lightweight belt located at the right edge of the recording paper. The marking stylus is attached to the belt. When the stylus is at the top of the paper a small mark is made. This is called the zero mark, and represents the surface of the water. The stylus continues to move down the edge of the paper while the sound pulse is traveling through the water, and when an echo is detected, the stylus makes another mark on the paper. The depth of the object which reflected the

echo can be read in feet by comparing its location on the paper to the depth scale printed on the paper.

A constant speed motor drives the paper graph. (The paper is treated so that the stylus will burn it to leave a permanent black mark.) During one revolution of the stylus belt, a very narrow mark will be made by the flexible stylus, but the paper will move a small amount before the next revolution. Each mark will blend into the one before, so that a composite "picture" of the target will be made, one tiny mark at a time.

Due to the many features that this unit has, we have split the operation section of this manual into two sections. The first part, Section III, is entitled "Basic Operation" and covers everything that is absolutely necessary to use your EAGLE in a wide variety of situations. It will tell you how to use the basic controls — Sensitivity, Suppressor, Paper Speed, GRAYLINE, Range, Marker, plus a few special functions. This section will be adequate for most situations. However, once you have mastered the basic operation of the EAGLE MACH 1, as described in Section III, you may wish to try some of the features

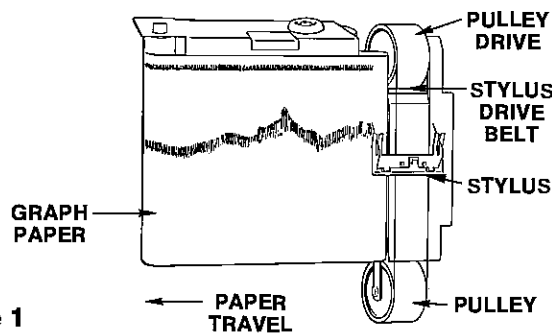

Figure 1

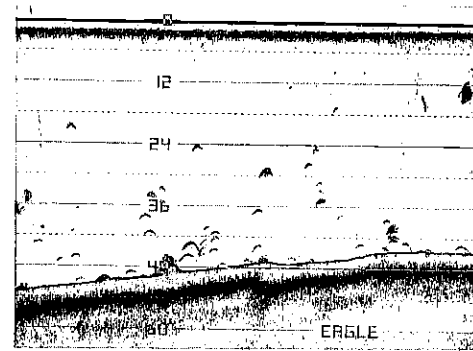

Figure 40

RANGE: 60 FEET
ZOOM: OFF
SENSITIVITY: 3/4

SUPPRESSOR: MINIMUM
LINES: ON
PAPER SPEED: 3/4
GRAYLINE: MINIMUM

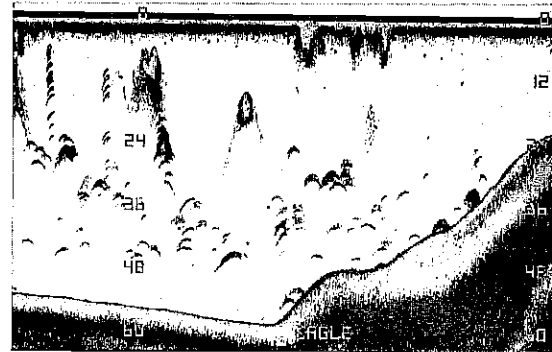

Figure 41

RANGE: 60 FEET
ZOOM: OFF
SENSITIVITY: 3/4

SUPPRESSOR: MINIMUM
LINES: OFF
PAPER SPEED: MAXIMUM
GRAYLINE: MINIMUM

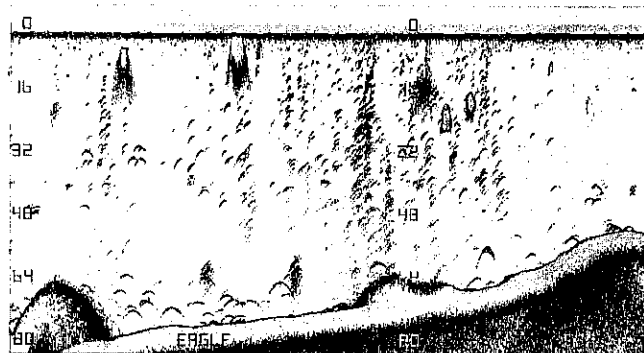

Figure 42

RANGE: 80 FEET
SENSITIVITY: MAXIMUM
SUPPRESSOR: MINIMUM

ZOOM: OFF
PAPER SPEED: MAXIMUM
LINES: OFF
GRAYLINE: MINIMUM

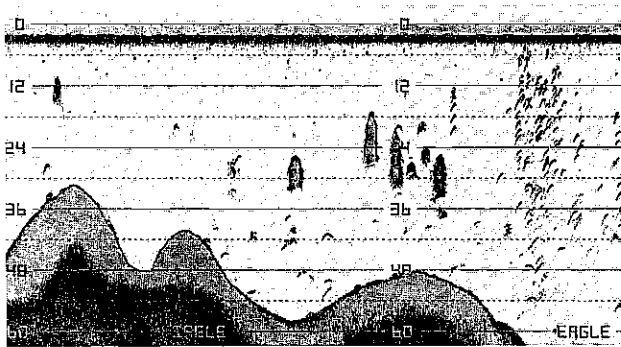

Figure 43

**RANGE: 60 FEET
SENSITIVITY: 3/4
SUPPRESSOR: MINIMUM**

**PAPER SPEED: MAXIMUM
LINES: OFF
ZOOM: OFF
GRAYLINE: MINIMUM**

SPECIFICATIONS

Operating Frequency . . . 192 kHz (192,000 cycles per second);
accuracy is within 0.6 percent.

Pulse Width 110-1400 us (ADJUSTABLE)
(Duration of Pulse)

Operating Voltage Minimum: 10 volts D.C.
Maximum: 15 volts D.C.

Operating Current 0.7 to 1.8 amps depending on printing
density and output power.

Output Power 1600 watts typical peak to peak.
(200 watts RMS)

Weight 7 lbs. 14 oz.

Dimensions Width-12 $\frac{1}{4}$ ", Height-9", Depth-6 $\frac{5}{8}$ "

NOTICE

Periodically wash the Transducer Face with soap and water to remove any oil film that may collect. Oil and dirt on the face will reduce sensitivity or may even prevent sounding.

INDEX

Introduction	2
How It Works	2
Installation	3
Basic Operation	4
Suppressor	5
Paper Speed	6
GRAYLINE®	7
Bottom Zoom	7
Range	7
Marker	8
End Of Paper	8
How To Read Graphs	8
Paper Loading	9
Stylus Replacement	12
Stylus Belt Replacement	12
Do's and Dont's	14
Troubleshooting	15
Advanced Operation	15
Scale	16
Specifications	20
Service Information	20

NOTE: This sonar uses LPG-605 Chart Paper.

HOW TO OBTAIN SERVICE

Eagle Electronics will provide quick and efficient service with genuine Eagle parts should you ever require it. If you do require service, call or write us at the address below before sending in the unit. We may be able to save you the inconvenience of sending the unit back for repairs. If you do have to return the unit for service, please enclose a letter stating the problem that you are having with the unit. This will assist us in the testing and repair of your depth sounder.

Mail to: **EAGLE ELECTRONICS**
P.O. BOX 669
CATOOSA, OKLAHOMA 74015

If you live out of the state of Oklahoma, call 1-800-331-2301.

If you live in the state of Oklahoma, call collect 918-266-5373.

SCHEMATIC DIAGRAM & PARTS LIST

Should you desire a schematic and parts list for your EAGLE depth sounder, send \$1.00 to the address above and it will be mailed to you promptly. Please be sure and give us the model and serial number of your EAGLE.



EAGLE

INSTALLATION AND OPERATION MANUAL

MODEL MACH 1

GRAPH RECORDER



EAGLE ELECTRONICS

P.O. BOX 669, CATOOSA, OKLA. 74015

LITHO USA

988-0095-01

A Division of:
Lowrance Electronics, Inc.